

# FORD TRUCKS 4148D EURO6

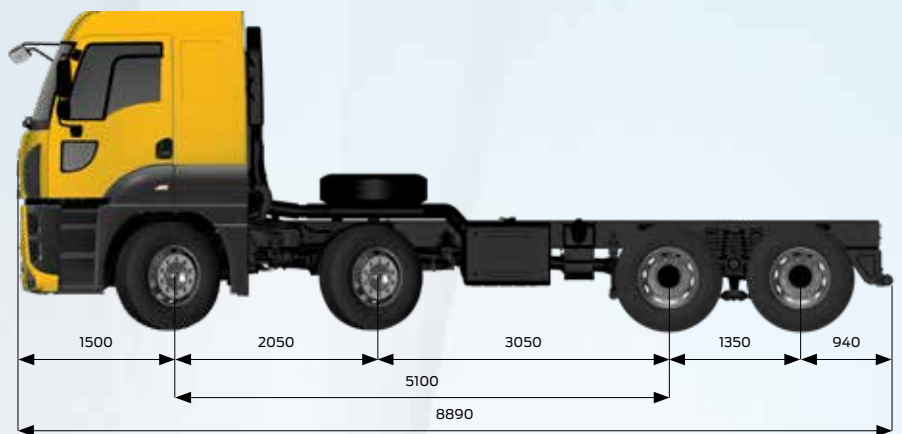
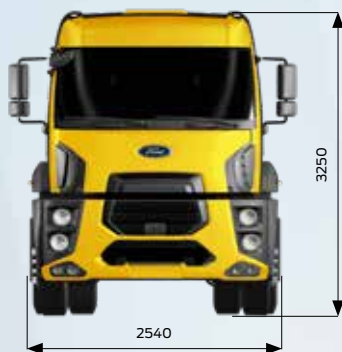

## Basic Features

Vehicle Type	Full Trailer / Tipper
Axle	8x4
Emission	Euro 6
Cabin Type	Extra High Roof Cab
Wheelbase (mm)	5100

## Engine

Type	Ecotorq 12.7 liter
Displacement [cc]	12740
Diameter x Stroke	130 mm x 160 mm
Power	480 PS (353 kW) / 1800 rpm
Torque	2500 Nm / 1000 - 1200 rpm
Compression Ratio	17 +/- 0,5 : 1
Oil Filling Volume [l]	50 L
Coolant volume [l]	57 L (with Intarder 77 L)

## Transmission

Clutch	2 x 400 mm Twin Clutch
Transmission	Ecotorq 16S 2600 OD AMT ( 14,107 – 0,823)

## Steering

Power Assisted Single Circuit

## Chassis

Chassis thickness [mm]	10 mm with Reinforcement
Chassis Strength [MPa]	500 MPa
Suspension (Rear/Front)	90 mm Parabolic Leaf Springs / Multileaf Tandem Suspension
Axle	Hub Reduction
Axle Ratio	3,57
Tyres	315/80 R22,5
Wheel Rim	22,5 x 9 Steel

## Braking System

Brakes (front/rear) (Ø.mm x mm. length)	410 x 200, Z-Cam Brake System
Braking System	Dual Brake Circuit – Air Processing Unit with Integrated Oil Separator and Heater
Engine Brake Power	max. 320 kW (Engine Level)
Intarder Power [Optional]	max. 600 kW / continuous 160 kW

## Electrical System

Battery	180 Ah
Alternator / Starter Motor	130 A / 6.5 kW

## Tanks

Fuel Tank	410 L
SCR Tank	55 L



Sharing the load

<b>Dimensions [mm]</b>					
Front Overhang	1500				
Wheelbase	5100				
Overall Length	8890				
Overall Vehicle Height	3631				
Overall Cab Length	2562				
Rear Overhang	996				
Useful Chassis Length	6494				
Ground Clearance - Front (Unladen)	377				
Ground Clearance - Rear (Unladen)	314				
Overall Vehicle Width (Excl. Mirrors)	2540				
<b>Weights [kg]</b>					
	1. Axle	2. Axle	3. Axle	4. Axle	Total
Technically Permissible Weights	8000	8000	13400	13400	35000
Kerb Weight	3934	3079	2245	2133	11391
Payload	4066	4921	11155	11267	23609
GTM					59000

### STANDARD EQUIPMENT

- Automated Transmission
- Air Conditioner
- Radio/Bluetooth/SD Card/USB
- Transmission (double gear) PTO without Flange
- Cruise Control
- Electrically Operated Windows
- Electrically Operated and Heated Side Mirrors
- Electrically Operated Headlamp Leveling
- Rake and Reach Adjustable Steering Column
- Heated and Air Suspended Driver Seat
- Power Sunroof
- Lumbar Support
- Anti-lock Brake System (ABS)
- Brake Lining Wear Sensor
- Immobilizer
- Single Key with Remote Control and Central Locking
- Home Safe
- Differential Lock
- Switchable Air Compressor (For Improved Fuel Economy)
- Medium Bumper
- Cab Air Suspension
- Electrically Operated Cab Tilting
- 27T Towing Capability

### OPTIONAL EQUIPMENT

- Hydraulic Retarder (Intarder)
- ADR Pack
- Wet Type Cab Heater
- Cold Pack with Wet Type Cab Heater
- Automatic Traction Control (ATC)
- Transmission (double gear) PTO with Flange
- 4750 mm Wheelbase (includes 250 L Fuel Tank)
- 6000 mm Wheelbase (includes 410 L Fuel Tank)
- 4.08 FDR with ZF 12TX 2210 Automated Transmission
- Short Bumper
- Less Spare Tire